

DESOLDERING PRODUCTS

Perfect for desoldering through-hole and multi-layered PCBs.

AUTOMATIC DESOLDERING STATION TP-200AS



- Built-in powerful and compact twin pump.
- When trigger is pulled, the heater heats up forcibly, reducing temperature decrease.
- After trigger release, the pump operates for approx. 0.5 seconds more, reducing solder clogs.



- POWERFUL VACUUM**
Everything from through-hole to multi-layered PCB
- CERAMIC HEATER WITH INTERNAL SENSOR**
A wide range for terminals, connectors and flat ICs
- ZERO VOLT SWITCH CIRCUIT**
Reduces noise during heater ON/OFF
- REPLACEABLE CARTRIDGE FILTER**
Makes changing the filter easy

ST-76 soldering iron stand (included)



For replacement tips, nozzles, and optional parts, refer to p. 63

Handy, portable Desoldering Gun with combined temperature-control circuit and desoldering mechanism

PORTABLE DESOLDERING GUNS TP-100/100AS



- POWERFUL VACUUM**
Everything from through-hole to multi-layered PCB
- ZERO VOLT SWITCH CIRCUIT**
Reduces noise during heater ON/OFF
- CERAMIC HEATER WITH INTERNAL SENSOR**
A wide range for terminals, connectors and flat ICs
- REPLACEABLE CARTRIDGE FILTER**
Makes changing the filter easy

- Compact design with an internal motor, pump, and temperature-control circuit built into the grip. Portable and efficient.
- Maximum vacuum of -0.08Mpa (-600 mmHg). Removes through-hole solder easily.
- Sensor feedback system allows temperature setting from 250-450°C.
- Makes changing the filter easy.

SPECIFICATIONS

MODEL	TP-100	TP-100AS
Voltage	110-130 V, 220-240 V AC 50/ 60 Hz	
Power Consumption	80 W (110-130 V), 70-75 W (220-240 V)	
Power Cord Length	1.5 m	
Temperature Setting Range	250-450°C	
Insulation Resistance	Over 100 MΩ (500 V DC)	
Vacuum Pump System	Diaphragm system	
Vacuum	- 0.08 MPa (-600 mmHg)	
Heater	Ceramic Heater	
Standard Nozzle	TP-100N-10	
Accessories	Cleaning pin TP-100CP-07/ Filter TP-100F	
	Carry case	
	Heat resistant pipe /Stand	
Dimensions	225 × 170 mm	
Weight	470 g (w/o cord)	

NOZZLE TEMPERATURE-RECOVERY FEATURES

Solder melted consecutively on 5 mm-dia land. Approx. 2 s / land. (with TP-100N-10 nozzle)

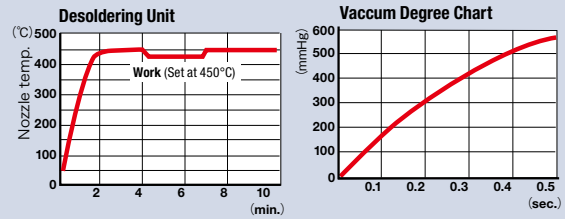

SPECIFICATIONS

MODEL	TP-200AS
Voltage	110 V,120-130 V, 220-240 V AC 50/ 60 Hz
Power Consumption	130 W (110 V,120-130 V) 170-200 W (220-240 V)
Power Cord Length	1.5 m
Temperature Setting Range	250-450°C
Insulation Resistance	Over 100 MΩ (500 V DC)
Vacuum Pump System	Diaphragm system
Vacuum	- 0.08 MPa (-600 mmHg)
Accessories	Cleaning pin TP-100CP-07 Soldering iron stand ST-76
Weight	Approx. 2.9 kg (w/o cord, hose)

CONTROL BOX

Output Voltage	110 V,120-130 V, 220-240 V AC
Dimensions	95 (W) x 205 (H) x 256 (D) mm
Weight	2.6kg (w/o cord, hose)

DESOLDERING UNIT

Input Voltage/Power Consumption	110-130 V, 220-240 V AC / 85 W
Heater	Ceramic Heater
Cord Length	1.2 m
Dimensions	220 × 155 mm
Weight	250 g (w/o cord, hose)
Standard Nozzle	TP-100N-10



For replacement tips, nozzles, and optional parts, refer to p. 63

REPLACEMENT TIPS

SVS-800AS/580AS/500AS

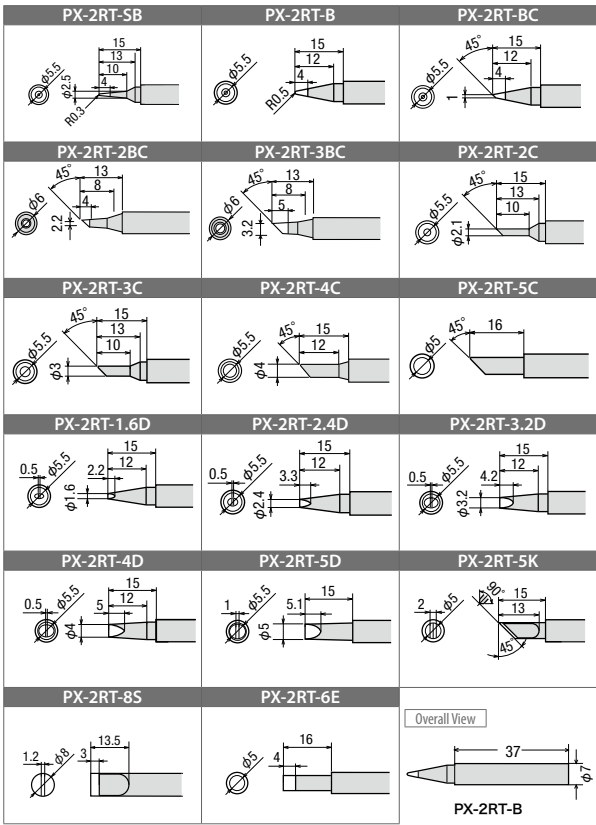

ROUND SOLDER-PLATED TIP

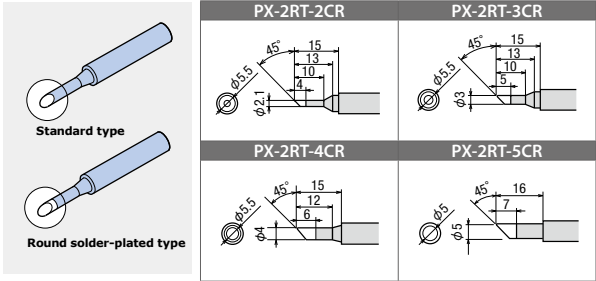

REPLACEMENT NOZZLES

SVS-800AS/580AS/500AS/TP-280AS/TP-200AS/TP-100(AS)

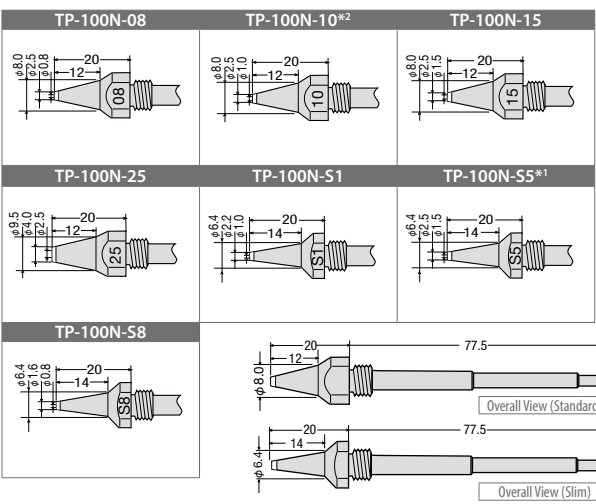

*1 Model SVS-800AS, SVS-580AS, TP-280AS Standard Nozzle: TP-100N-S5
 *2 Model SVS-500AS, TP-200AS, TP-100(AS) Standard Nozzle: TP-100N-10

REPLACEMENT PARTS / OPTIONS

REPLACEMENT PARTS FOR SVS-800AS/580AS/500AS

*Desoldering Unit for SVS-800AS/SVS-580AS TP-28GAS	Iron Unit (common for SVS series) SVS-50GAS
Desoldering Unit for SVS-500AS TP-20GAS	Heater for Soldering Iron SVS-500H-1
Heater for Desoldering Gun TP-100H	Heater Barrel for Soldering Iron TQ-77HP(S)
Heater Barrel for Desoldering Gun TP-100HP	Spacer for Soldering Iron TQ-77SS
	Collar for Soldering Iron TQ-77NUT

*TP-28GAS Desoldering Unit is not interchangeable with TP-20GAS (SVS-500, SVS-500AS, SVS-550AS)

REPLACEMENT PARTS FOR TP-280AS/200AS

*Desoldering Unit for TP-280AS TP-28GAS	Desoldering Unit for TP-200AS TP-20GAS
Heater TP-100H	Heater Barrel TP-100HP

*TP-28GAS Desoldering Unit is not interchangeable with TP-20GAS (TP-200, TP-200AS, TP-250AS)

REPLACEMENT PARTS FOR TP-100/100AS

Heater TP-100H	Heater Barrel TP-100HP
--------------------------	----------------------------------

COMMON PARTS

Filter	
Filter Set (3pcs) TP-100F	Steel Wool Only (3pcs) TP-100UL
Cartridge Set TP-100K	Felt B (10pcs) TP-100RFT
Felt Set (3pcs) TP-100FT	

Cleaning Pin Vice	Cleaning Pin
Pin vice body (The drill bit is not included.) TP-100PV	Ø0.7 mm (for Ø0.8 & 1.0 mm nozzle) TP-100CP-07
Drill Bit Ø0.7 mm TP-100DB-07	Ø1.3 mm (for Ø1.5 & 2.5 mm nozzle) TP-100CP-13
Drill Bit Ø0.9 mm TP-100DB-09	
Drill Bit Ø1.4 mm TP-100DB-14	
Drill Bit Ø2.4 mm TP-100DB-24	

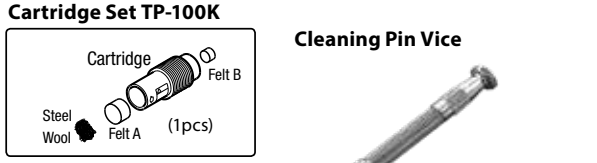
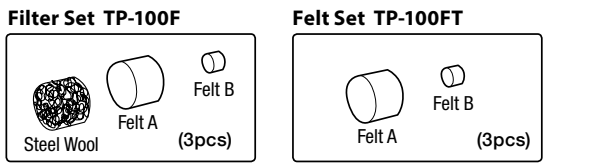

Iron Unit SVS-800AS, SVS-580AS, SVS-500AS

