

ASA 伺服螺絲鎖付系統功能特色

Features of ASA Servo Screwdriver



單控制器可驅動2把螺絲起子
1 controller activates 2 Servo screwdriver.



扭力閉環控制、重複精度高
Torque closed-loop control, repeatability with high precision.



500個機種、500顆螺絲設定
Supports 500+ and max. 500 screw types data settings.



可實現滑牙、浮牙等多種不良品分析機制
Problem analysis: stripped / floating screw...etc.



數據可追溯
Data traceability.



提高生產力
Improves productivity.



扭力、角度、貼合點控制與監控
Torque, angle, seating point control strategy and monitoring.



擰緊中確保工具正確、程式在正確工序中被使用，提高產品質量並減少材料浪費
Improves process control and product quality; decreases material waste.

常見螺絲鎖付品質議題 Tightening Quality Issues

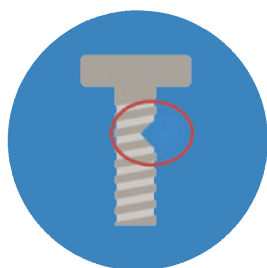

螺絲損壞檢測
Defective screw thread

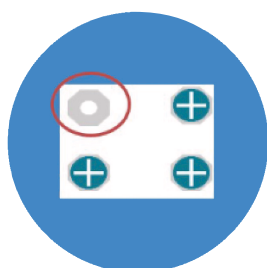

漏鎖檢測
Missing screw

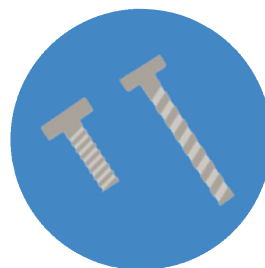

裝錯螺絲檢測(長的裝成短的)
Wrong screw

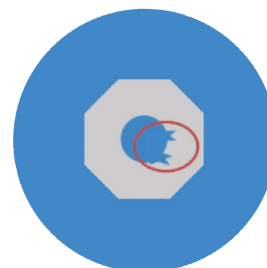

螺孔有問題
Defective screw hole

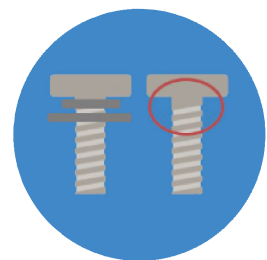

墊片漏裝檢測
Missing washer



鎖過緊
Over-tightening

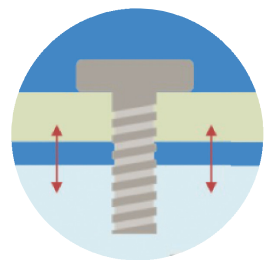

浮牙檢測
Floating screw

ASA 常見螺絲鎖付品質議題

Tightening Quality Issues

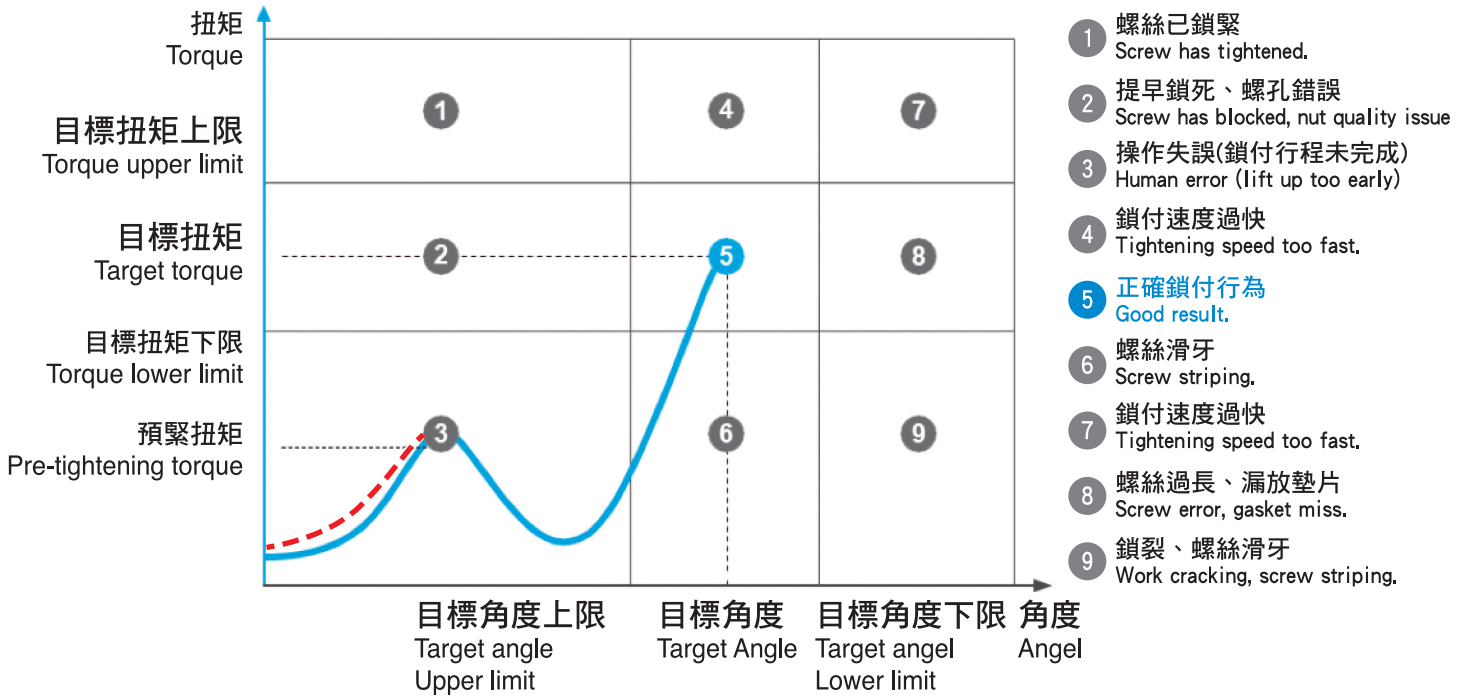

常見螺絲鎖付品質議題 Tightening Quality Issues

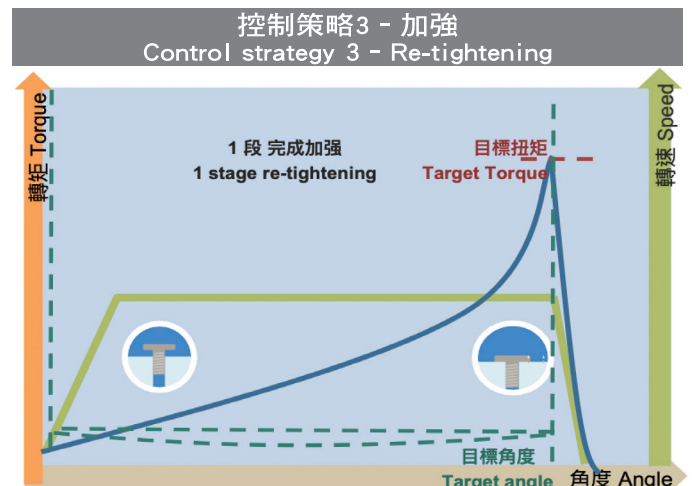
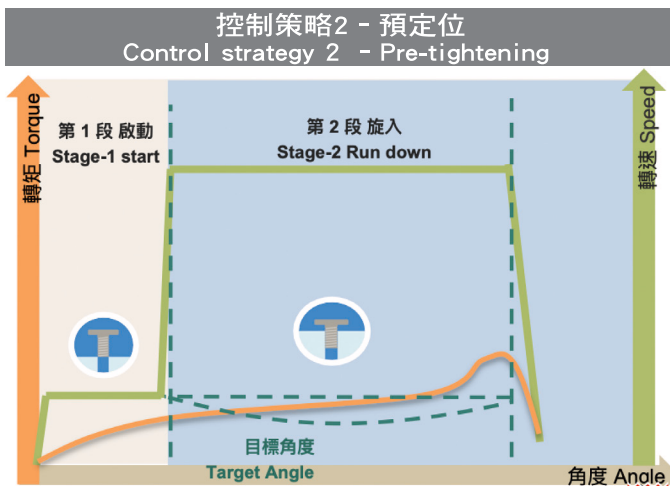
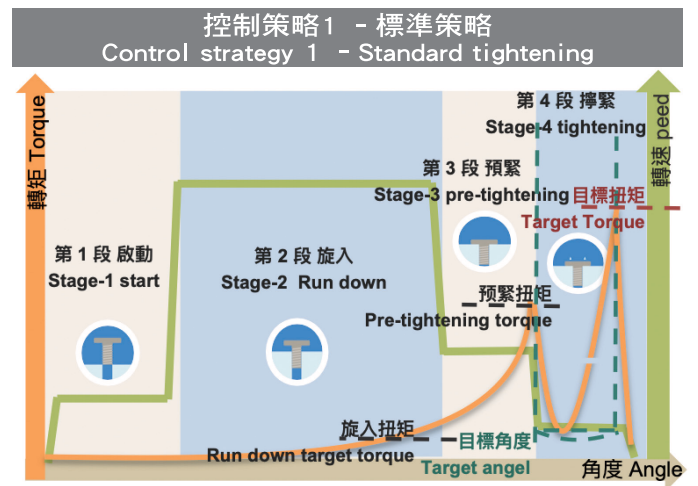
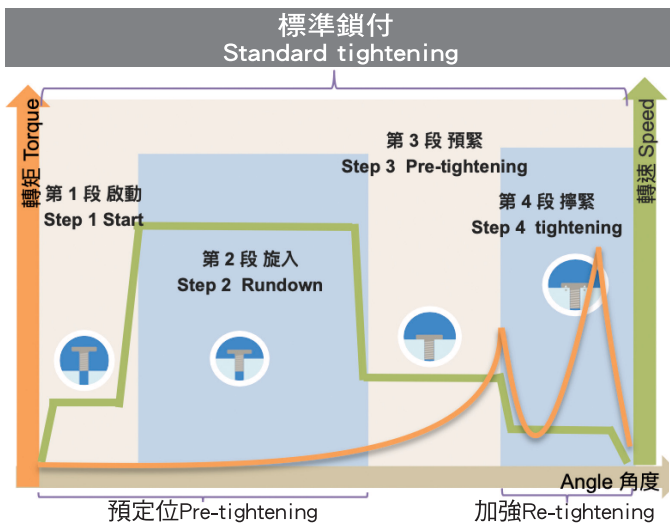

MES



ASA 伺服螺絲鎖付系統的架構

ASA Servo Screwdriver Structure



伺服螺絲鎖付控制器
Servo tightening controller



高速通訊
High speed communication

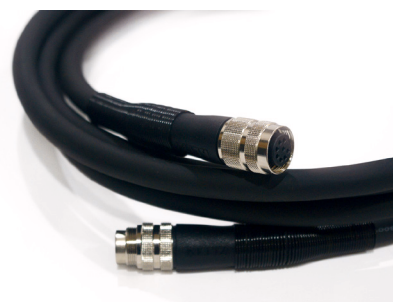

高精度的位置回授編碼器
Precisely position feedback encoder

高精度扭力傳感器直接回授全閉環控制
Closed-loop control with high precision torque sensor

低頓扭矩直流伺服馬達
Low-cogging-force DC servo motor

高速通訊連接電鎖與驅動器
High speed communication with servo drive and screwdriver

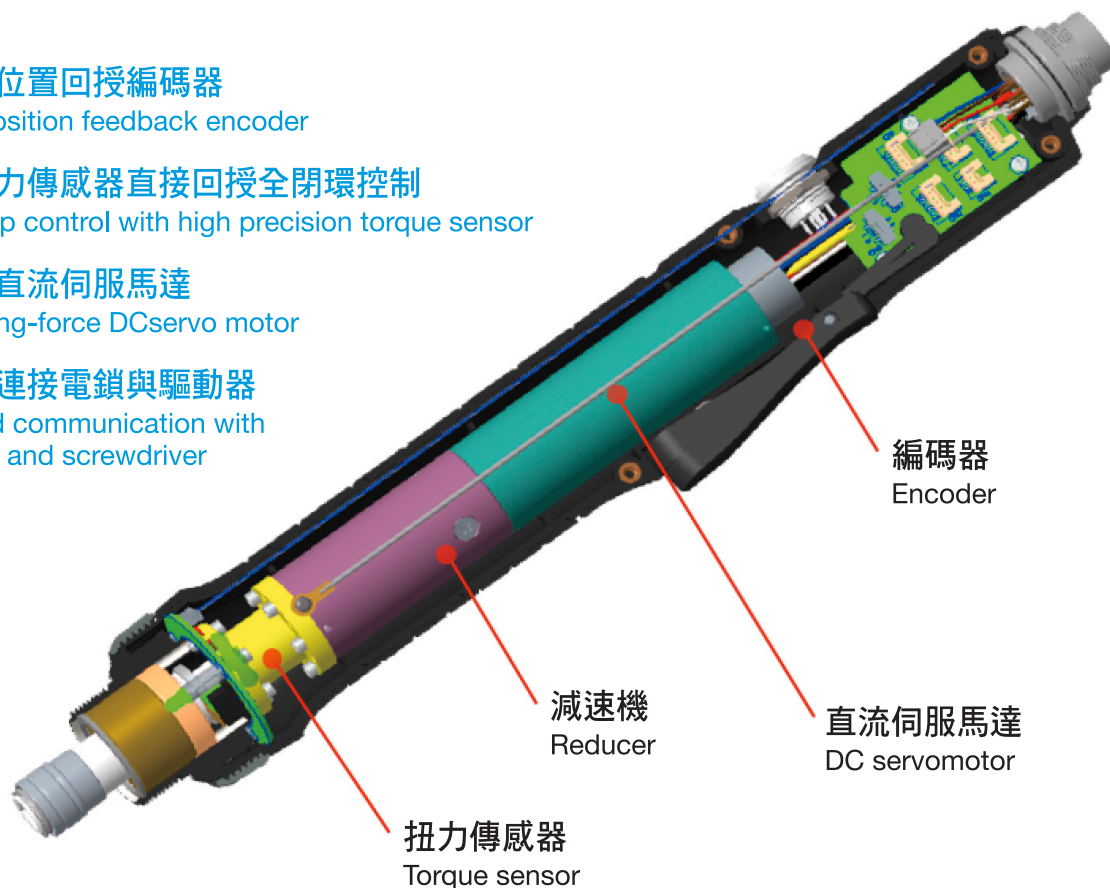



伺服螺絲鎖附控制器 ASA Servo Screwdriver Controller

- 一對二高效能控制器
 - 可依情境選擇雙軸同動或雙軸交互作業
 - 10.1吋大畫面，可同時或獨立顯示2把伺服螺絲起子的作業結果
 - 大容量記憶體，可獨立紀錄200,000筆以上鎖附結果
-
- One-To-Two High Performance Controller
 - Can work with 2 Screwdrivers either simultaneously or interchangeably
 - 10.1-inch Large Screen
Can display either One or Two Transducer Screwdriver working results
 - Large Memory Capacity
Can store more than 200,000 records

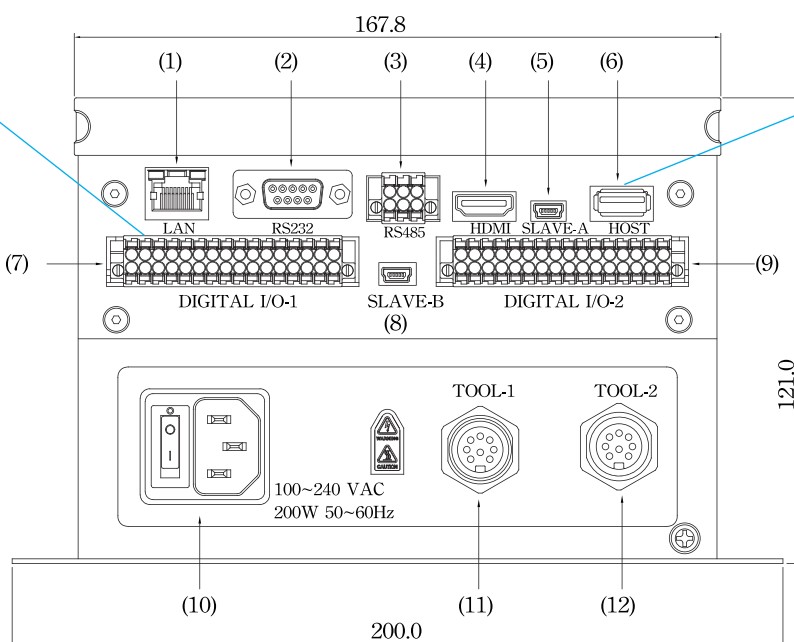



ASA 伺服螺絲鎖付伺服器 ASA Servo Screw Tightening Controller



伺服螺絲鎖付控制器 Servo Screw Tightening Controller

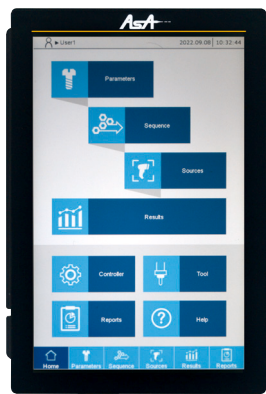

伺服螺絲起子 Servo Screwdriver



控制器 Controller	規格 Specifications	
型號 Model name	ST1-1	ST1-2
輸入電壓 Input voltage	100~240VAC	
Dc bus 電壓 DC bus voltage	38 VDC	
額定輸出電流 Rated out current	3.7 Arms	7.4 Arms
額定輸出功率 Rated output power	100W/單軸 (1把) 100W/1-axis (screwdriver)	200W / 雙軸 (2把) 200W/2-axis (screwdrivers)
螢幕尺寸 Screensize	10.1" (觸控 螢幕 touchscreen)	
外觀尺寸 Dimensions(mm)	200 x 252 x 121 (寬width) x (高height) x (深depth)	
重量 Weight	4.06 kg	
安規認證 Approval by	CE, UKCA	

尺寸圖 Dimension

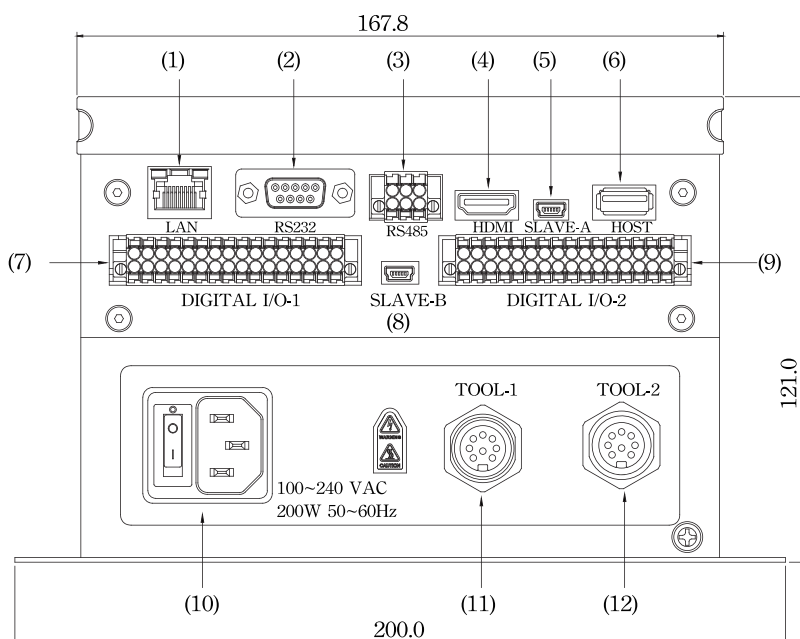
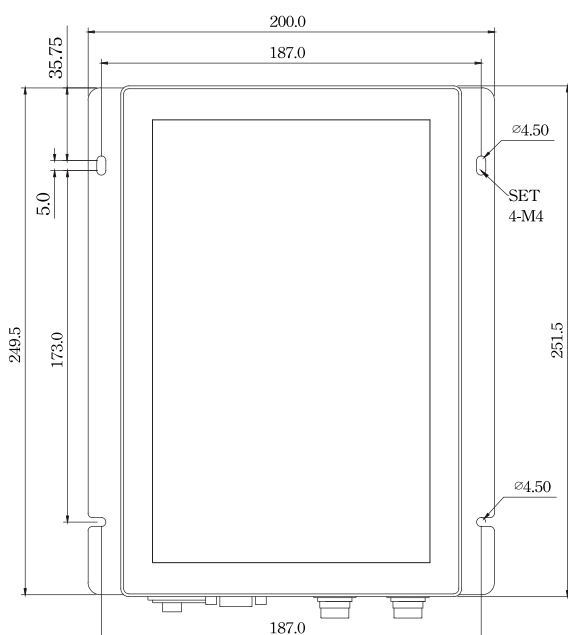



型號 Model name	ST1-12SA ST1-12SB	ST1-30SA ST1-30SB	ST1-50SA ST1-50SB	ST1-75SA
啟動方式 Starting Method	槓桿式 / 下壓式 (可任意切換) Lever start / Push to start (switchable)			
輸入電壓 Input voltage	38Vdc			
扭力範圍 Torque range(kgf·cm)	2.4~12	6~30	10~50	15~75
精確度 Precision	±3%			
最高轉速 Max. speed	2000 rpm	1100 rpm	700 rpm	500 rpm
電鎖長度 Length	271 mm			
重量 Weight	480 g			
手握直徑 Handheld O.D. (mm)	34 mm			
起子頭尺寸 Available bit size	5.0mm/6.35mm(1/4") 六角對邊 Hex shank			6.35mm(1/4") 六角對邊 Hex shank
操作溫度 Operating temperature	0°C~40°C			
儲存溫度 Storage temperature	0°C~60°C			
濕度 Humidity	0~90% RH (non-condensing)			
防護等級 IPclass	IP40			

*A表6.35mm(1/4")六角起子頭，B表5mm六角起子頭 *A for 6.35mm(1/4") Hex shank，B for 5mm Hex shank

伺服螺絲鎖付系統-週邊設備(選購品) Attachment of Servo Screwdriver(Optional)

名稱 Description	規格 Specification
DC電源線-3m DC Cable-3m	2W2140
DC電源線-5m DC Cable-5m	2W2142
DC電源線-10m DC Cable-10m	2W2144
90度彎頭 Right angle head	4A9110
槍型握把 Gun type-grip	4A9317
自動機台轉接座 Screwdriverholder (for EQ)	4V3034

尺寸圖 Dimension

