

AT-01SC-DC-V3 BS Type
Counter with Power Supply
User Manual



Thank you for buying .Please read this Owner's User Manual before using it with your screwdriver

Please Keep this User Manual for Future Reference

1 Making Initial Setting of Counter

In order to start setting up counter , first turn on the counter from on/off switch on front.

Long press MENU button for 2-3 seconds to enter into settings menu. You see as below on display to set count. Press ▲ and ▼ keys to set the desired count min. 1 and max. 99.

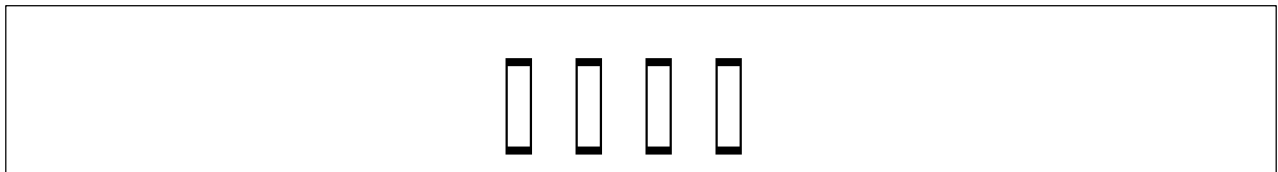

Press again MENU button again, use ▲ and ▼ keys to set if RESET button is enabled or disabled when keypad locked

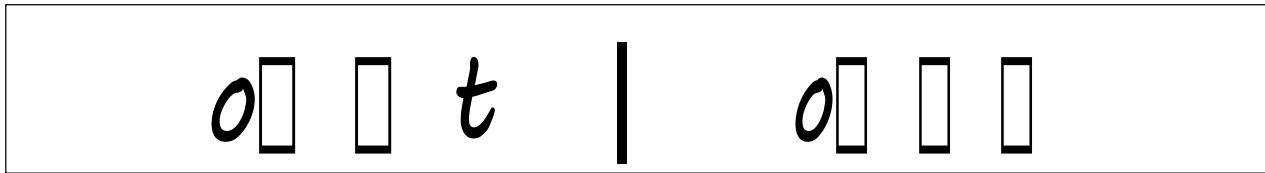

Press again MENU button again, use ▲ and ▼ keys to set if BYPASS button is enabled or disabled when keypad locked

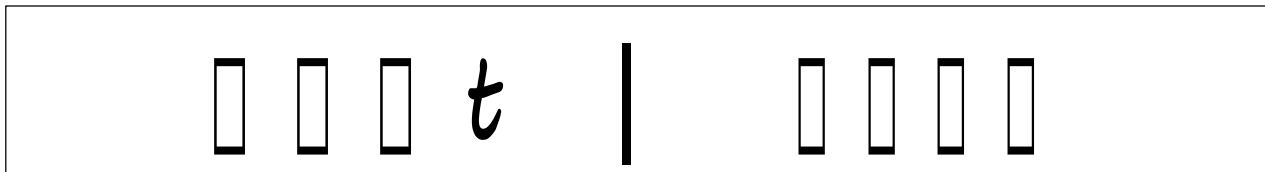

Press again MENU button again, use ▲ and ▼ keys to set the no of Inputs 1 , 2 , 3 or □ □ (always ON on first input and pulse input on 2nd input and Reset on 3rd input , used for clamp type)

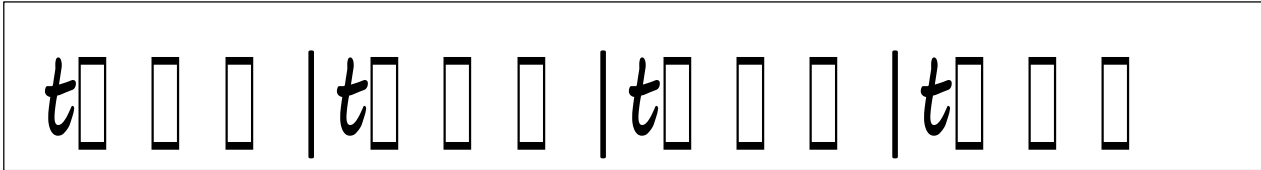

Press again MENU button again, use ▲ and ▼ keys to set type of output , *Pass and Fail type* or *Clamp lock and unlock type* or *Pulse type Pass Fail output*

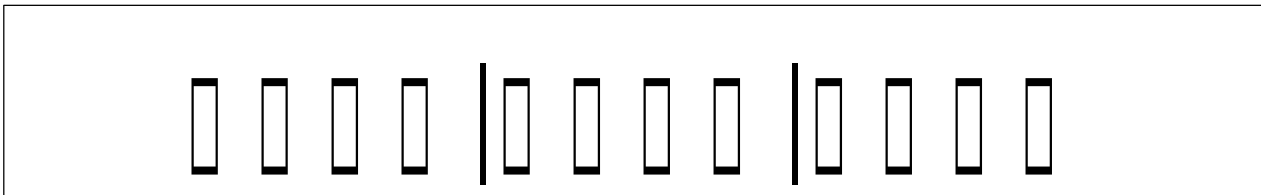

Press again MENU button again, use ▲ and ▼ keys to set type of sensor , NPN type Sensor or PNP type Sensor

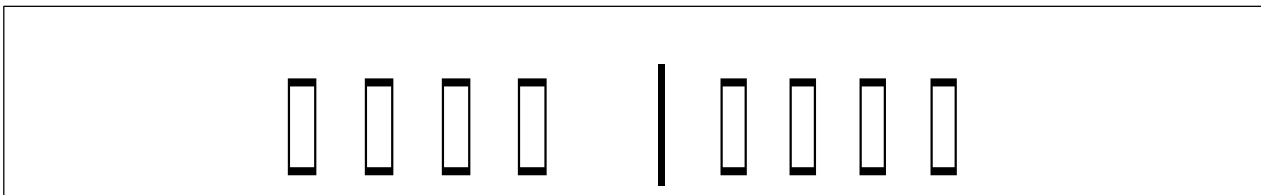

Press again MENU button again, use ▲ and ▼ keys to set if display should count down or up i.e. descending or ascending ,

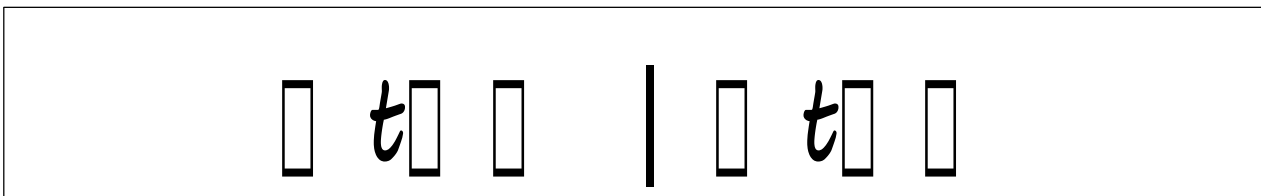

Press again MENU button again, use ▲ and ▼ keys to set Job ID Enabled or Job ID disabled

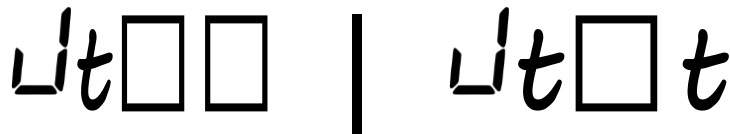

Handwritten text: Lit□□ | Lit□t

If Job ID is enabled then press MENU again then 16 different JOB counts can be set one by one from □ , □ , □ ...to □ by using the ▲ and ▼ keys.

Now Setting of Counter is complete.

Long Press MENU button to exit settings menu, now Counter display as follows :-



Four vertical rectangular boxes representing a counter display.

The first two digits is the set count and last 2 digits decrement/increment count when job starts.

When the JOB fails the counter keeps beeping every seconds until it is reset.

2 Counter functioning

The counter functioning is explained in steps as follows:-

- 1. The Inputs are turned on.**
- 2. The Counter gives power to the screwdriver. If output type is clamp then clamp close is turned on.**
- 3. The display shows the set count in first 2 digits and last 2 digits show the no of screws remaining.**
- 4. The operator tightens set no of screws and counts decrements/increments .**
- 5. On every screw tightened properly there is a pulse output on green wire as shown in wire diagram below.**
- 6. When the set no of screws fastened the supply to screwdriver is cut and pass led is turned on and output (either pass or clamp open is turned on as set by user).**
- 7. If job fails that is set no of screw not fastened and job removed from jig the power to screwdriver is cut and fail led turned on and output (either fail or clamp close turned on as set by user).**
- 8. When job fail the counter keeps beeping every seconds until it is reset.**
- 9. In case of fail if bypass button is enabled then long press bypass to turn on screwdriver and correct job .**
- 10. Then the job cycle can be repeated as above.**

If RESET and BYPASS buttons are disabled they will still keep working if keypad is not locked, keypad must be locked with 3 digit code to disable them if user has disabled either or both of them in menu.

3 Locking/Unlocking Front Keypad of Counter

To lock the keypad to avoid accidental press or avoid the counter settings to be changed to wrong parameters , Long Press the LOCK button for 2-3 seconds. Display shows as below

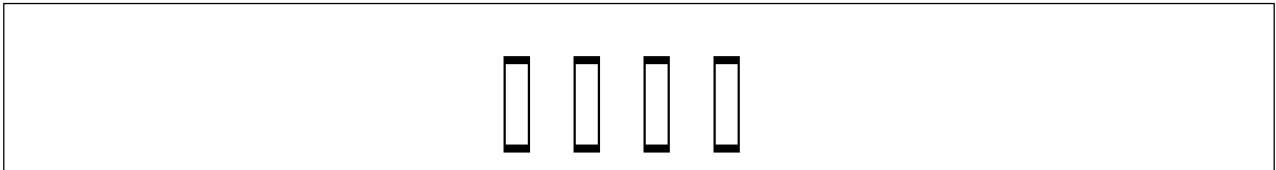

Use ▲ , ▼ and MENU to set the 1st , 2nd and 3rd digit of key , min. 000 and max. 999.

Long press LOCK key after setting your desired key , then the display shows follows and then goes back to normal display of Count and now the 2nd digit decimal turns on to indicate that keypad is locked

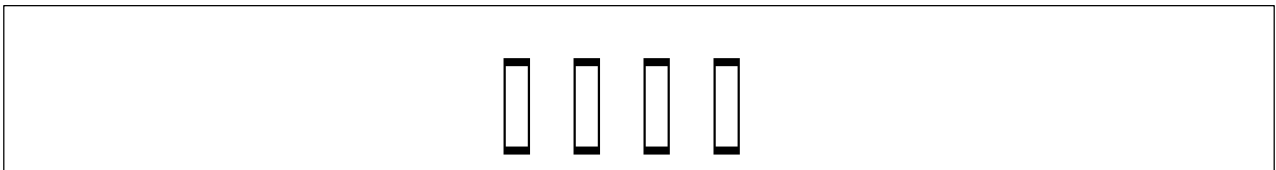

When Keypad is locked, to Unlock long press LOCK button and Enter your lock key set , just like you set the lock key with help of ▲ , ▼ and MENU . Then long press LOCK key again to unlock keypad , you see below as follows if key is correct and keys are unlocked.

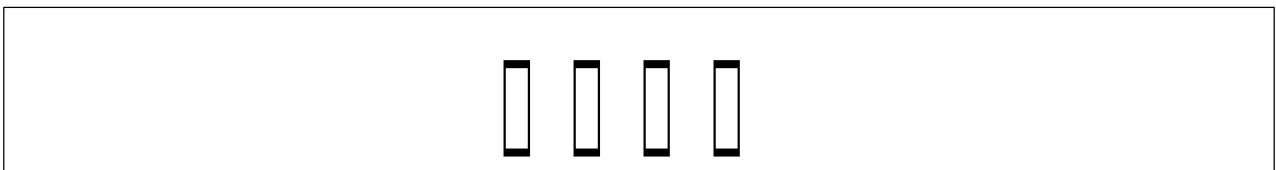

If you enter the wrong key then the following is display and keypad is not unlocked.

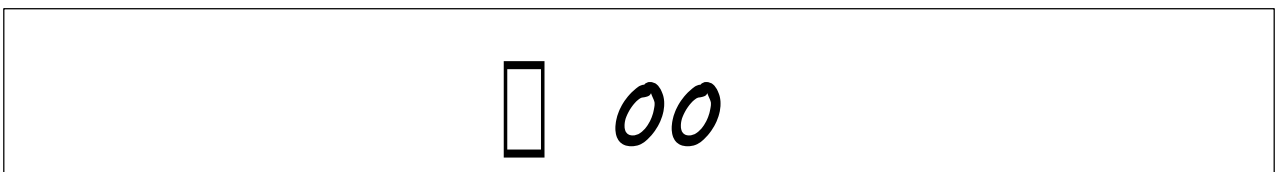

4 JOB ID

JOB ID function maybe enabled or disabled depending on need of user. JOB ID feature can help quickly change No of Screw for different Jobs set by USER to help in quick changeover to new type of JOB without going into Menu everytime . If JOB ID is enabled then user can enter 16 different counts according to their needs. The 5 core wire for JOB ID can then be shorted in different combinations as below in table to change to different count as set by user in menu.

JOB ID				
All wires short to Black Wire				
Job No.	Red	Yellow	Blue	Green
0	OPEN	OPEN	OPEN	OPEN
1	OPEN	OPEN	OPEN	CLOSE
2	OPEN	OPEN	CLOSE	OPEN
3	OPEN	OPEN	CLOSE	CLOSE
4	OPEN	CLOSE	OPEN	OPEN
5	OPEN	CLOSE	OPEN	CLOSE
6	OPEN	CLOSE	CLOSE	OPEN
7	OPEN	CLOSE	CLOSE	CLOSE
8	CLOSE	OPEN	OPEN	OPEN
9	CLOSE	OPEN	OPEN	CLOSE
a	CLOSE	OPEN	CLOSE	OPEN
b	CLOSE	OPEN	CLOSE	CLOSE
c	CLOSE	CLOSE	OPEN	OPEN
d	CLOSE	CLOSE	OPEN	CLOSE
e	CLOSE	CLOSE	CLOSE	OPEN
f	CLOSE	CLOSE	CLOSE	CLOSE

5 Connecting Inputs

The Connection to the 3 inputs for the counter is shown in below circuit diagram in case when NPN NO sensor or PNP No Sensor is used and also when normal NO switch/relay output is used. The Counter outputs 24V power in case sensor needs to be connected.

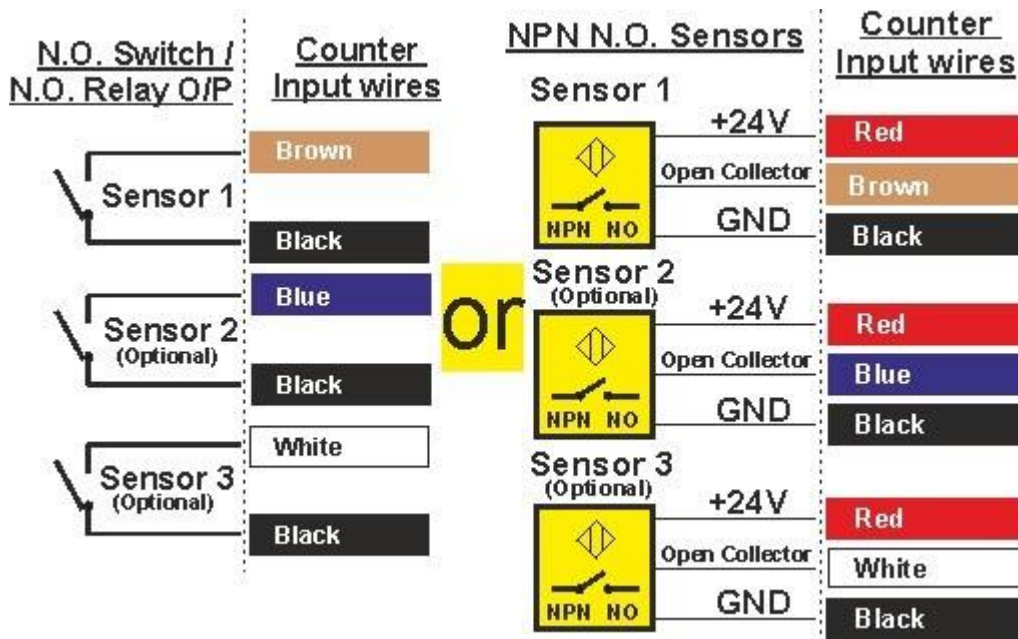

6 Connecting External Reset and Bypass

External Switches can be used as follows in case the user need to use some other external switch to bring out these buttons for their use instead of using the ones on counter front panel.

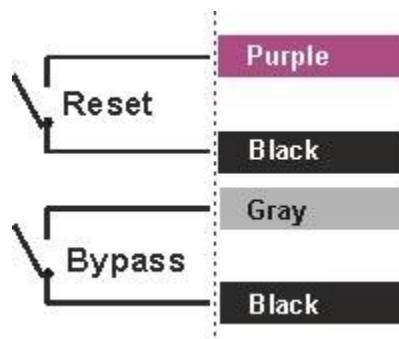

7 Connecting Outputs

The Connection for the 3 Counter outputs is shown in below circuit diagram. Both 24V Output are capable of outputting 5W max.

